

perFORMA320-420 ThermoForm Ambalaj Makinası

perFORMA320 fonksiyonel thermo-form ambalaj makinası

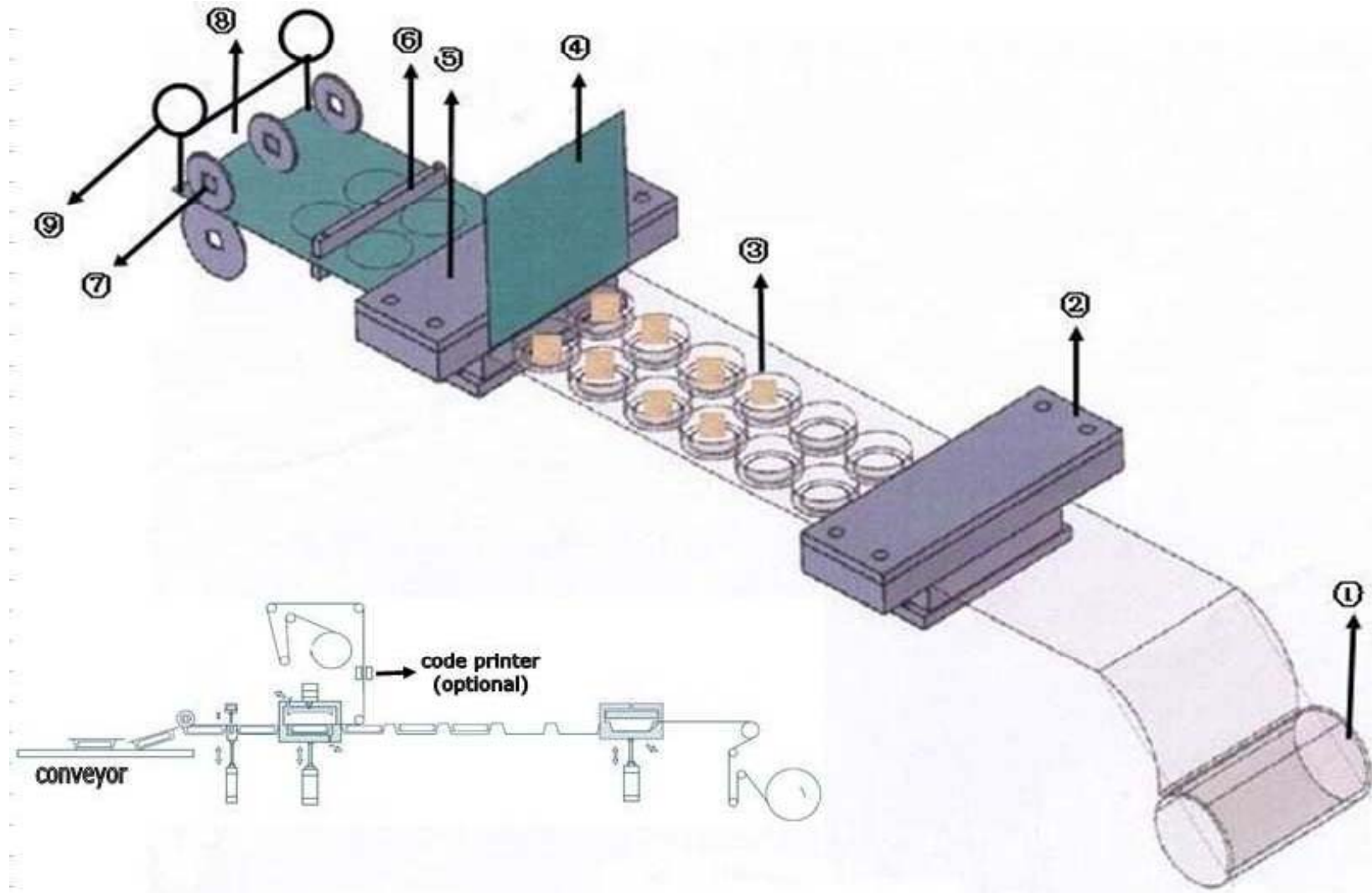

perFORMA 320

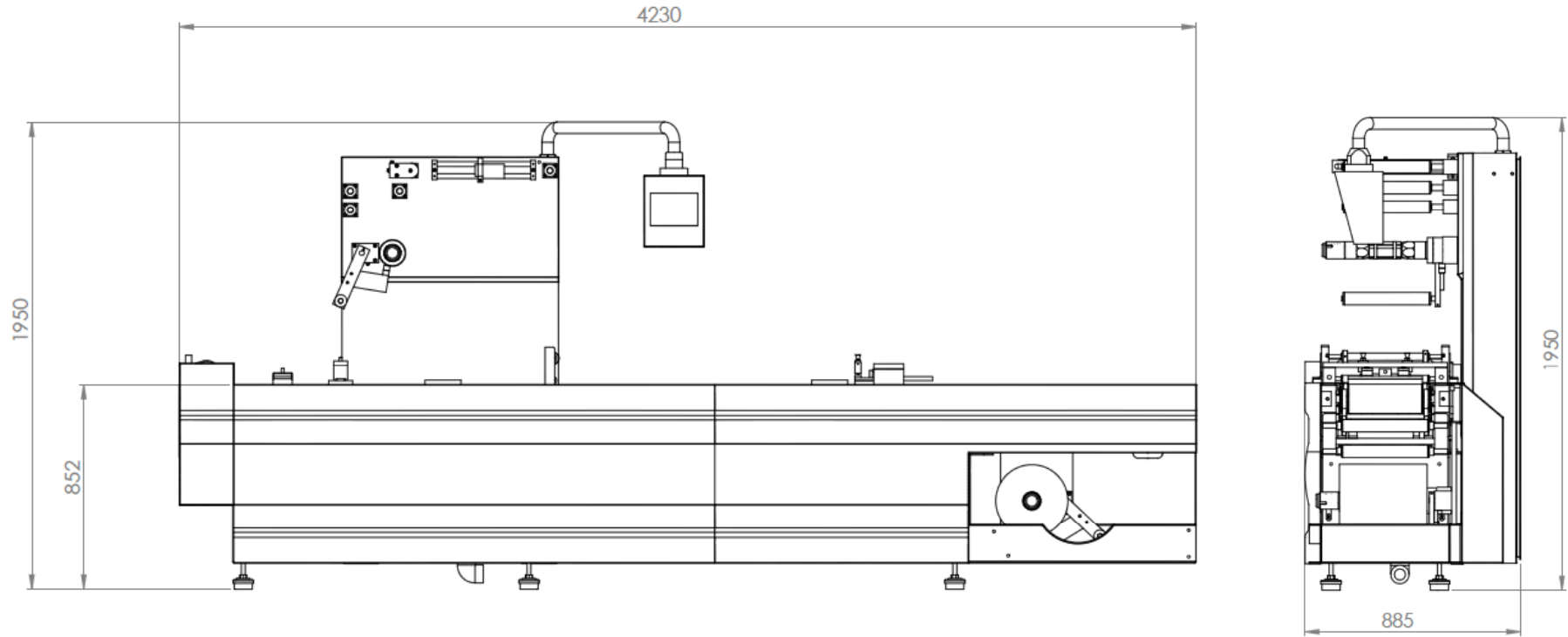

	perFORMA		
Teknik özellikler	320	360	420
Makine boyu	4.150 mm		
Makine eni	1.070 mm		
Makine yüksekliği	1.700 mm		
Enerji, kW	3/N/PE AC 400V 50 Hz Min 4 > 10 kw		
Basınçlı hava	Min 6 bar 400-600 nl/dakia		
Soğutma suyu	60-80 lt/saat		
Üst film özelliği	Yumuşak Film 80-150 mikron		
Form genişliği	300 mm	340 mm	400 mm
Üst film dış çapı	300 mm		
Alt film özelliği	Yumuşak ve yarı sert 130-400 mikron		
Alt film dış çapı	350 mm		
Kapasite	6-8 işlem/dakika		

	perFORMA			
Standart adım	200 mm	240 mm	270 mm	300 mm
Net yükleme bölümü	1.000 mm	1.200 mm	1.080 mm	1.200 mm
Net yükleme adımı	5	5	4	4
Thermo-form derinliği	max 140 mm			
	STANDART		OPSiYON	
Basıncılı hava ile form verme	■		vakum 60 m3/h	
Alüminyum dolgu plakaları	■			
Düz Form plakaları	■			
Çizgili form plakaları	YOK		kalıba bağlı olarak	
Form genişliği	300 mm	340 mm	400 mm	
Üst film dış çapı	300 mm			
Vakum sistemi	no		100/160 m3/s	
Gaz verme sistemi	no		■	
Düz kaynak plakası	■			
Kaynak istasyonu plastik dolgu plakaları	■			

Bottom film 320 mm.

CUT OFF LENGTH / INDEX LAENGE

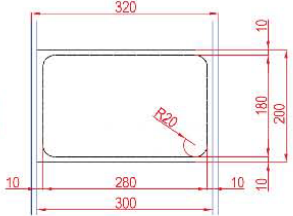
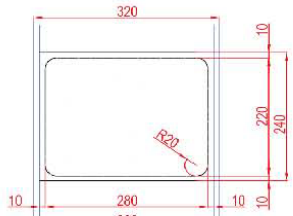
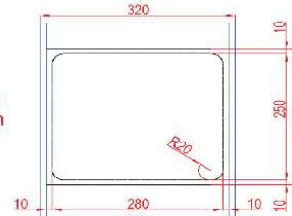
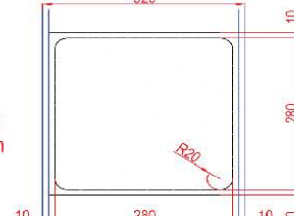
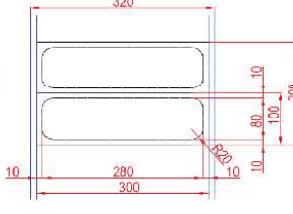
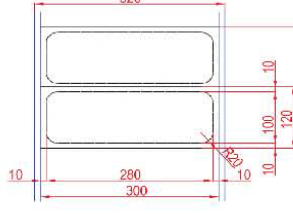
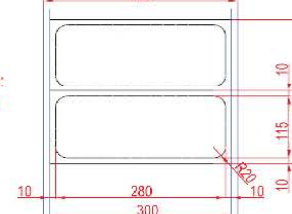
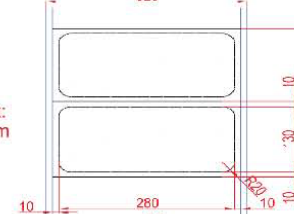
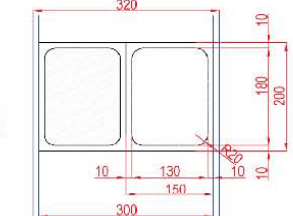
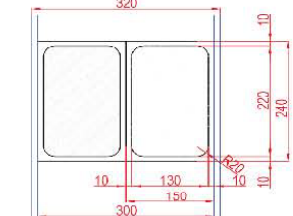
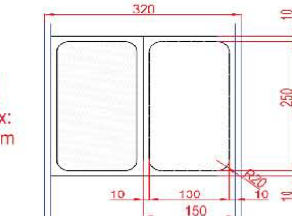
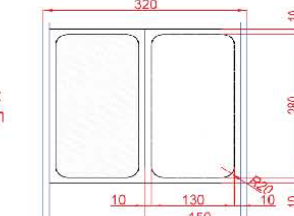
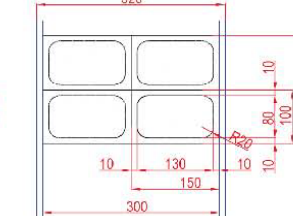
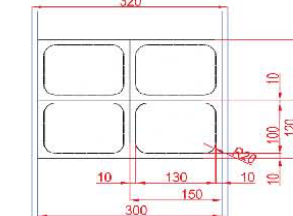
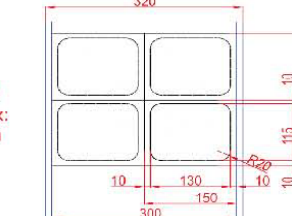
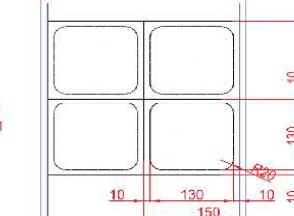
200	240	270	300
<p>1.1 H.Max: 120mm</p> 	<p>1.1 H.Max: 120mm</p> 	<p>1.1 H.Max: 120mm</p> 	<p>1.1 H.Max: 120mm</p> 
<p>1.2 H.Max: 60mm</p> 	<p>1.2 H.Max: 80mm</p> 	<p>1.2 H.Max: 90mm</p> 	<p>1.2 H.Max: 100mm</p> 
<p>2.1 H.Max: 100mm</p> 	<p>2.1 H.Max: 100mm</p> 	<p>2.1 H.Max: 100mm</p> 	<p>2.1 H.Max: 120mm</p> 
<p>2.2 H.Max: 60mm</p> 	<p>2.2 H.Max: 80mm</p> 	<p>2.2 H.Max: 90mm</p> 	<p>2.2 H.Max: 100mm</p> 

Bottom film 320 mm.

CUT OFF LENGTH / INDEX LAENGE

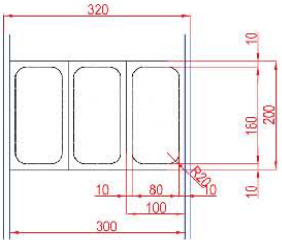
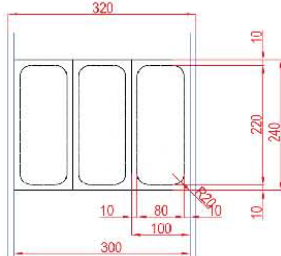
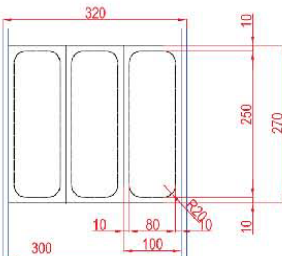
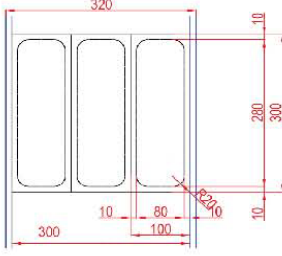
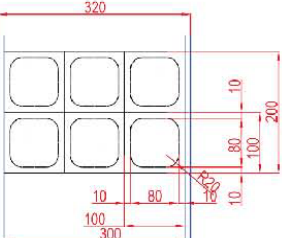
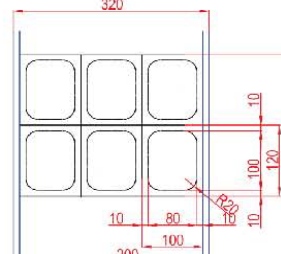
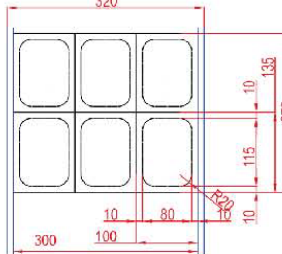
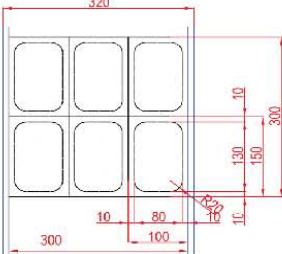
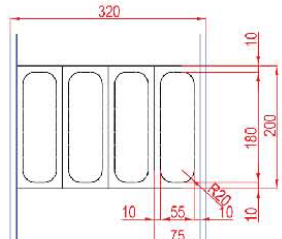
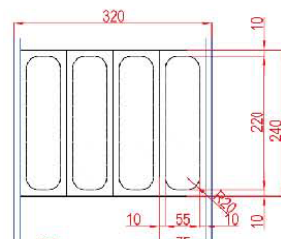
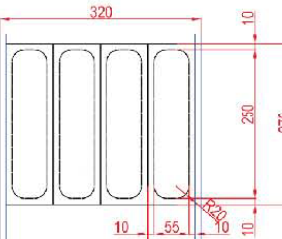
200	240	270	300
<p>3.1 H.Max: 60mm</p> 	<p>3.1 H.Max: 60mm</p> 	<p>3.1 H.Max: 60mm</p> 	<p>3.1 H.Max: 60mm</p> 
<p>3.2 H.Max: 60mm</p> 	<p>3.2 H.Max: 60mm</p> 	<p>3.2 H.Max: 60mm</p> 	<p>3.2 H.Max: 60mm</p> 
<p>4.1 H.Max: 40mm</p> 	<p>4.1 H.Max: 40mm</p> 	<p>4.1 H.Max: 40mm</p> 	<p>4.1 H.Max: 40mm</p> 